

IUW

Ultrasonic bulk water meter for use in drinking water distribution and industrial applications

The IUW ultrasonic bulk water meter is used to record high and fluctuating flows in drinking water distribution and in industry, with a very low pressure loss at the same time. Two pairs of ultrasonic sensors ensure optimum measurement accuracy. The IUW is factory-fitted with a 9-digit LCD display and an NFC interface. This enables a subsequent connection of a wM-Bus (OMS) or LoRaWAN®-NDC module. Via the plug and play function of the NDC module, the radio technology set on the meter is automatically adopted by the NDC module. All variants are approved for any installation and are therefore also suitable for riser and downpipe installation. A head-down mounting is also possible. All materials, which are used in the drinking water section, comply with the required standards, guidelines and the current German drinking water approval (other country-specific drinking water approvals on request).



Performance characteristics at a glance

- Switchable radio technology
- Highest precision and reliability even in case of low flow rates
- Protection class IP68
- No moving parts in the flow sensor
- Insensitive to deposits and particles
- No straight inlet or outlet needed (U0/D0) according to OIML R49 and DIN EN ISO 4064
- Battery powered LCD register with NFC interface
- Smart functions
- Alarm and statistic functions
- Galvanically separated NFC interface
- Battery life > 15 Years
- Operating pressure MAP 16
- Approved in accordance with MID
- Plug and play detection of radio technology via NDC radio module
- Configuration-App
- Mechanical/electromagnetic environment class M2/E2

Applications

- For measuring the consumption of cold and clean drinking water or service water up to 50° C
- For measuring high flow rates

AMR options

- NFC interface (= Near Field Data Capture) for connecting an external NDC module and for device configuration

Readout options of the measuring device via the NFC interface (Near Field Communication)

- Device ID (serial number)
- Current (balanced) consumption display or Total volume in case of an overflow
- Date / Time
- Firmware version
- Up to 15 previous month's value
- Temperature
- Key date / key date volume
- Flow volume / return volume
- Alarm or error message
- Battery end

Technical data

Nominal diameter	DN	mm	50	50	65	65	80	80	100
Permanent Flowrate	Q ₃	m ³ /h	25	40	40	63	63	100	100
Attainable measuring range	Q ₃ /Q ₁	R	500	800	500	800	500	800	500
Standard measuring range ¹	Q ₃ /Q ₁	R	500	500	500	500	500	500	500
Overload Flowrate	Q ₄	m ³ /h	31,25	50,00	50,00	78,75	78,75	125,00	125,00
Overload Flowrate max.	Q _{4M}	m ³ /h	55,00	55,00	87,00	87,00	138,00	138,00	220,00
Minimum flowrate ²	Q ₁	m ³ /h	0,10	0,16	0,16	0,25	0,25	0,40	0,40
Transitional flowrate ²	Q ₂	m ³ /h	0,16	0,26	0,26	0,40	0,40	0,64	0,64
Lower measuring limit	-	l/h	25	25	40	40	63	63	100
Display range	min	l	1	1	1	1	1	1	1
	max	m ³	999.999	999.999	999.999	999.999	999.999	999.999	999.999
Temperature range	-	°C	0,1 - 50	0,1 - 50	0,1 - 50	0,1 - 50	0,1 - 50	0,1 - 50	0,1 - 50
Operating pressure	MAP	bar	0,3 - 16	0,3 - 16	0,3 - 16	0,3 - 16	0,3 - 16	0,3 - 16	0,3 - 16
Pressure loss class at Q ₃	Δp	bar	0,16	0,25	0,16	0,25	0,10	0,10	0,10
Mechanical environmental condition	-	-	M2	M2	M2	M2	M2	M2	M2
Electromagnetic ambient class ⁴	-	-	E2	E2	E2	E2	E2	E2	E2
Climatic environment ³	-	°C	5 - 55	5 - 55	5 - 55	5 - 55	5 - 55	5 - 55	5 - 55
Flow profile sensitivity	-	-	U0/D0	U0/D0	U0/D0	U0/D0	U0/D0	U0/D0	U0/D0

Dimensions and weights:

Nominal diameter	DN	mm	50	50	65	65	80	80	100
Overall length	L	mm	200/270	200/270	200/300	200/300	225/300/350	225/300/350	250/350/360
Height	H	mm	60	60	73	73	94	94	104
Height	H1	mm	150	150	165	165	203	203	221
Width	B	mm	120x120	120x120	145x145	145x145	= D	= D	= D
Width	B1	mm	135	135	150	150	< D	< D	< D
Flange diameter	D	mm	165	165	185	185	200	200	220
Bolt circle diameter	D1	mm	125	125	145	145	160	160	180
Number of bolts	-	pcs.	4	4	4	4	8	8	8
Screw size	-	mm	M16	M16	M16	M16	M16	M16	M16
Bolt diameter	-	mm	19	19	19	19	19	19	19
Weight approx.	-	kg	7,0/8,8	7,0/8,8	8,7/10,8	8,7/10,8	11,6/12,6/13,9	11,6/12,6/13,9	13,7/16,2/16,3

¹ Other measuring ranges (R) on request

² Values refer to standard measuring range

³ Condensation possible

⁴ During electromagnetic interference, there may be disruptions in the data transmission between the NFC interface and the NDC module, which can lead to a lack of radio transmission. However, the counting progress on the measuring device itself is not affected.

Attention: not all versions are available in all markets

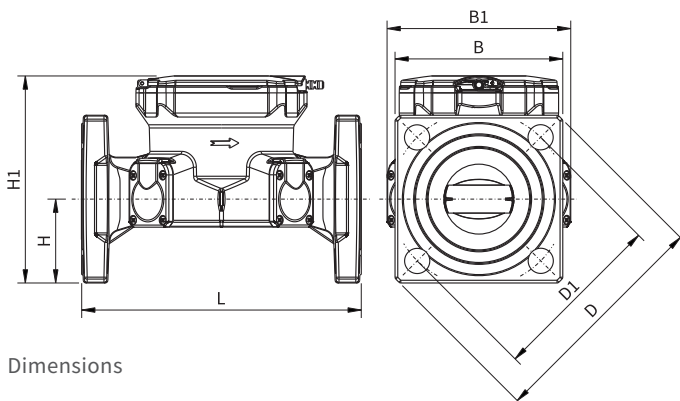

Dimensions

Technical data

Nominal diameter	DN	mm	100	125	125	150	150	200
Permanent Flowrate	Q_3	m^3/h	160	160	250	250	400	400
Attainable measuring range	Q_3/Q_1	R	800	500	800	500	800	500
Standard measuring range ¹	Q_3/Q_1	R	500	500	500	500	500	500
Overload Flowrate	Q_4	m^3/h	200,00	200,00	312,50	312,50	500,00	500,00
Overload Flowrate max.	Q_{4M}	m^3/h	220,00	344,00	344,00	550,00	550,00	865,00
Minimum flowrate ²	Q_1	m^3/h	0,64	0,64	1,00	1,00	1,60	1,60
Transitional flowrate ²	Q_2	m^3/h	1,03	1,03	1,60	1,60	2,56	2,56
Lower measuring limit	-	l/h	100	100	250	250	250	400
Display range	min	l	1	1	1	10	10	10
	max	m^3	999.999	999.999	999.999	9.999.999	9.999.999	9.999.999
Temperature range	-	°C	0,1 - 50	0,1 - 50	0,1 - 50	0,1 - 50	0,1 - 50	0,1 - 50
Operating pressure	MAP	bar	0,3 - 16	0,3 - 16	0,3 - 16	0,3 - 16	0,3 - 16	0,3 - 16
Pressure loss class at Q_3	Δp	bar	0,10	0,10	0,10	0,10	0,10	0,10
Mechanical environmental condition	-	-	M2	M2	M2	M2	M2	M2
Electromagnetic ambient class ⁴	-	-	E2	E2	E2	E2	E2	E2
Climatic environment ³	-	°C	5 - 55	5 - 55	5 - 55	5 - 55	5 - 55	5 - 55
Flow profile sensitivity	-	-	U0/D0	U0/D0	U0/D0	U0/D0	U0/D0	U0/D0

Dimensions and weights:

Nominal diameter	DN	mm	100	125	125	150	150	200
Overall length	L	mm	250/350/360	250	250	300/500	300/500	350
Height	H	mm	104	117	117	135	135	162
Height	H1	mm	221	247	247	277	277	326
Width	B	mm	= D	= D	= D	= D	= D	= D
Width	B1	mm	< D	< D	< D	< D	< D	< D
Flange diameter	D	mm	220	250	250	285	285	340
Bolt circle diameter	D1	mm	180	210	210	240	240	295
Number of bolts	-	pcs.	8	8	8	8	8	12
Screw size	-	mm	M16	M16	M16	M20	M20	M20
Bolt diameter	-	mm	19	19	19	23	23	23
Weight approx.	-	kg	13,7/16,2/16,3	16,4	16,4	24,1/29,4	24,1/29,4	35,5

¹ Other measuring ranges (R) on request

² Values refer to standard measuring range

³ Condensation possible

⁴ During electromagnetic interference, there may be disruptions in the data transmission between the NFC interface and the NDC module, which can lead to a lack of radio transmission. However, the counting progress on the measuring device itself is not affected.

Attention: not all versions are available in all markets

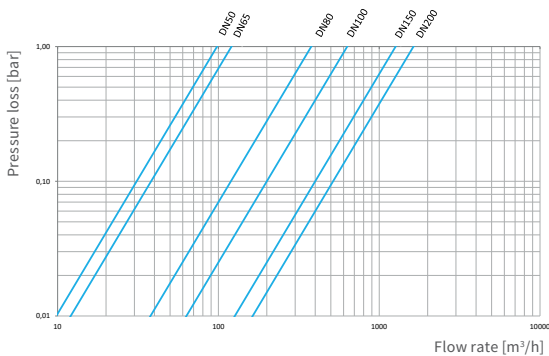

Pressure loss curve

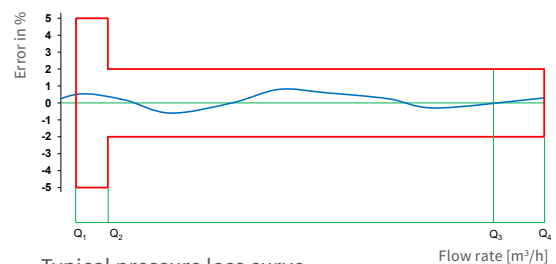

Typical pressure loss curve

ZENNER International GmbH & Co. KG

Heinrich-Barth-Straße 29
66115 Saarbrücken
Germany

Phone +49 681 99 676-30
Fax +49 681 99 676-3100
E-Mail info@zenner.com
Internet www.zenner.com