

zelsius® C5-CMF

Thermal energy meter with measuring capsule flow sensor (CMF)

Connection interfaces according to DIN EN ISO 4064-4

Optional interfaces: M-Bus, wireless M-Bus, LoRa® and 3 pulse inputs or outputs

Nominal sizes: q_p 0.6 to 2.5 m³/h

The thermal energy meter (also called heat or cold meter) zelsius® C5-CMF with measuring capsule flow meter combines compactness with rugged construction. The calculator on the zelsius® C5-CMF is removable as standard with a cable length of approx. 1.2 m and provides a real practical advantage in tight spaces and transfer stations with covers. A matching wall adapter with mounting hardware is included in the delivery.

The flow sensor on the zelsius® C5-CMF has electronic, non-reactive impeller scanning and has metrological approval for horizontal and vertical installation (downpipe and riser) according to the current European Measuring Instruments Directive 2014/32 /EU (MID).

The zelsius® C5-CMF is ideally suited for continuous use during regular meter replacement as well as for installation in pre-equipped single-pipe connectors in new measuring points thanks to the large selection of directly compatible and commercially available connection interfaces.

System components for remote meter reading, customer service and MID compliant accessories for the direct installation of temperature sensors make the zelsius® C5-CMF an optimal solution for practical use.



Performance characteristics at a glance

- Directly compatible with many commercially available connection interfaces in accordance with DIN EN ISO 4064-4 (formerly DIN EN 14154)
- Standard removable calculator, connection cable length to the flow sensor approx. 1.2 m for high flexibility in tight installation situations
- Optionally with contemporary data communications interfaces by wire (M-Bus) and radio (wireless M-Bus and LoRa®) as well as three programmable pulse inputs and outputs
- OMS certification for BSI-compliant smart meter gateway connection
- Available as combined heat/cooling energy meter with automatic switching

Technical data flow sensor type CMF
(Values for symmetrical installation of temperature sensor pair)

Nominal flow q_p	m ³ /h	0.6	1.5	2.5
Maximum flow q_s	m ³ /h	1.2	3.0	5.0
Minimum flow q_i	l/h	24	30 / 60	50 / 100
Starting flow horizontally ca.	l/h	5	5	7
Pressure loss at q_p	bar	≤0.25 bar		
Medium temperature range	°C	10 ≤ θ_q ≤ 90		
Minimum pressure (to avoid cavitation)	bar	0.3		
Measurement accuracy class		3		
Connecting interface type ¹		IST, TE1, A1, PCC, M60		
Nominal pressure / peak pressure	PS/PN	16		
IP protection class		54 (65 for combined heating and cooling energy metering)		
Installation position		horizontal, horizontal tipped through 90° or vertical		
Installation point		return flow, optionally forward flow		
Cable length up to calculator	m	1.2		
Installation place temperature sensors		M10x1, tangential to measuring capsule (except type A1)		
Heat carrier		Water		

¹ optional

Dimensions

Height	(H1 _{max} + H2)	H _{max} = 65 mm H1 _{max} = 40 mm H2 = 25 mm
--------	--------------------------	---

Connecting sizes

Nominal flow	q_p	m ³ /h	0.6	1.5	2.5
Threaded connection	DN	mm	15	15	20
Installation length	L	mm	110	110	130
Threaded connection		inch	3/4	3/4	1

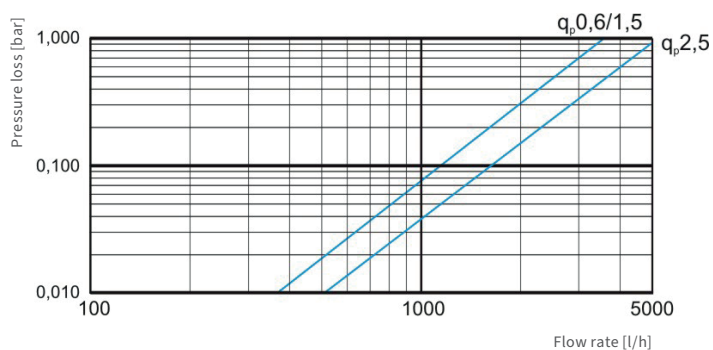

Pressure loss curve

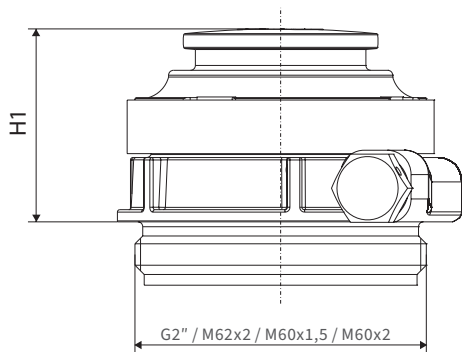
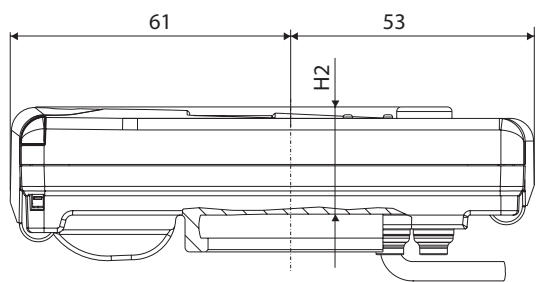

Combi version type IST, TE1, M60, PCC

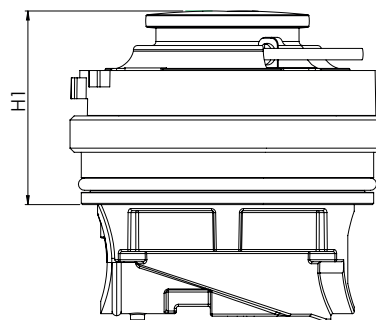
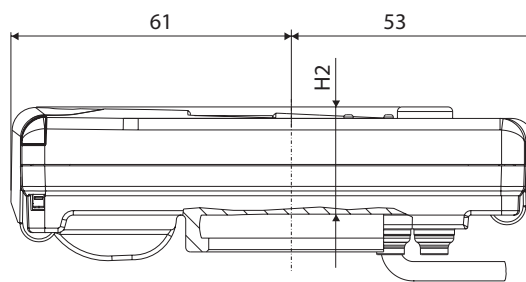

Combi version type A1 (M77x1,5)

Technical data calculator

Temperature range	°C	0...105
Temperature difference range	K	3...80
Display range		LCD 8-digit + additional character
Ambient temperature during operation	°C	5...55
Storage temperature	°C	-20...+65
Temperature resolution	°C	0.01

Measurement frequency	s	Standard: 30 For models with M-Bus interface: 10 Optional: 4
-----------------------	---	--

Heat consumption display		Standard: MWh Optional: kWh, GJ
--------------------------	--	------------------------------------

Data storage		1 x daily
--------------	--	-----------

Data log		Annual due date values for heating and/or cooling energy: Storage over the whole running time for readout on the display (the last two annual reference date values can be read out via data telegram)
		Monthly values for heating and/or cooling energy as well as volumes: Storage over the whole running time for readout on the display (the last 24 monthly values can be read out via data telegram)
		Maximum values for flowrate and heating/cooling power: Storage of the absolute values since commissioning the meter as well as 12 monthly values, both with date and time
		Operation hours since commissioning the meter

	Standard	optical interface (ZVEI, IrDA)
--	----------	--------------------------------

Interfaces	optional	<ul style="list-style-type: none"> 3 pulse inputs/ outputs M-Bus (2400 baud, unlimited readout frequency, remote supply via M-Bus level converter, power consumption <1.5 mA, transmission of consumption and instantaneous values) wireless M-Bus: Generation 4, OMS-certified, setting options via app "ZENNER Device Manager Basic": Mode T1 or C1, Encryption Level 5 or 7, various transmission intervals and telegram contents, radio ON / OFF, transmission power: ≤25 mW (14 dBm) LoRa®: Daily values or monthly values (incl. half monthly values), Diagnosis protocol³, Transmission power ≤25 mW (14 dBm)
------------	----------	--

Power supply		3.6 V lithium battery (different capacities)
--------------	--	--

Battery lifetime ²	Years	≥7, optional ≥10
-------------------------------	-------	------------------

IP protection class		54
---------------------	--	----

Ambient class		C in accordance with DIN EN 1434-1
---------------	--	------------------------------------

Ambient conditions / influencing factors (valid for complete compact meter)	- climatic	Highest permissible ambient temperature 55 °C Lowest permissible ambient temperature 5 °C
	- mechanical class	M1
	- electromagnetic class	E1

² The validity period for the calibration depends on the country, please observe the relevant national regulations.

³ Values for energy and volume increment as well as the average and maximum return temperature within the transmission interval (15 minutes to 1 day can be chosen) are transmitted by the meter. Values for the average supply temperature, temperature difference, thermal power and flowrate are or can be calculated by the LoRa Server based on the energy and volume increment. See also separate description.

Technical data temperature sensors

Platinum precision resistor		Pt 1000
-----------------------------	--	---------

Sensor type ¹	mm	according to the model: 45 x 5.0 mm / 45 x 5.2 mm DS 6 / DS 27.5
--------------------------	----	--

Temperature range ¹	°C	0...105 / 0...150
--------------------------------	----	-------------------

Cable length	m	1.5 (opt. 5)
--------------	---	--------------

In the case of new installation of meters with nominal flowrates of ≤q_n 6 m³/h and nominal pressures of ≤PN 16 directly immersed in the heat carrier.

Installation point
For calibration exchange in existing measuring points with immersion sleeves with an overall length of ≤60 mm, please observe the separate information "Installation in existing immersion sleeves" as well as the immersion sleeve tolerance list from PTB (download at www.ptb.de).

¹ optional

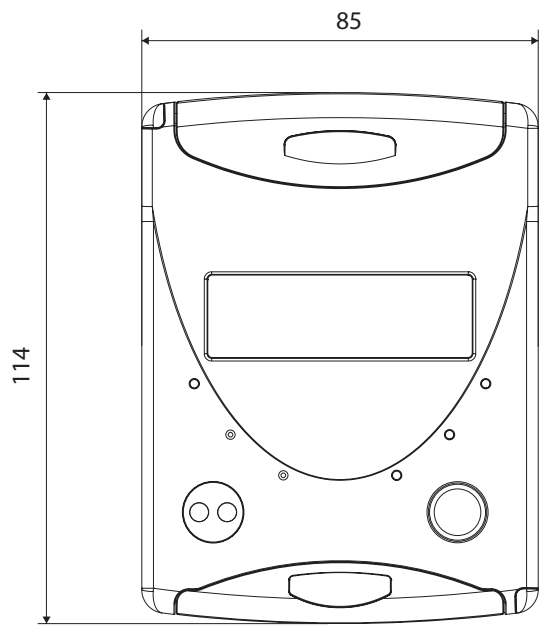

Dimensions data calculator

Exchange options for existing meters

Type Ista
IST, G2"



C5-CMF IST

Type Techem
TE1, M62x2



C5-CMF TE1

Type Allmess
A1, M77x1.5



C5-CMF A1

Type Minol
M60, M60x1.5



C5-CMF M60

Type Sensus
PCC, M60x2

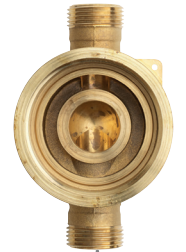

C5-CMF PCC

Installation of temperature sensor

Installation with existing ball valves



with adapter



Temperature sensor
PSC 45 x 5.2 mm
or 45 x 5.0 mm



Temperature sensor
DS 27,5 („AGFW-sensor“)
or DS 6

Installation with existing immersion sleeves



Temperature sensor
PSC 45 x 5.2 mm
or 45 x 5.0 mm
or DS 6

zelsius® C5-CMF

Further zelsius® C5-Versions:



zelsius® C5-ISF
Compact meter with single-jet
flow sensor (ISF)



zelsius® C5-IUF
Compact meter with ultrasonic
flow sensor (IUF)

ZENNER International GmbH & Co. KG

Heinrich-Barth-Straße 29
66115 Saarbrücken
Germany

Phone +49 681 99 676-30
Fax +49 681 99 676-3100
E-Mail info@zenner.com
Internet www.zenner.com